

Operation Manual

**MULTICHANNEL
DIGITAL DYNAMIC
STRAIN METER**

DS-50A



Tokyo Sokki Kenkyujo Co., Ltd.

NOTICE





This manual describes how to operate multichannel digital dynamic strain meter DS-50A and its operation procedures.

Please read this operation manual thoroughly to familiarize yourself with the functions and operating procedures of this product. It will enable you to make maximum use of all its functions and take precise measurements effectively.

Please keep this manual always ready to use.

When you read this manual

This manual uses following symbols to describe important items. Please read carefully.

 Danger	If you ignore this indication and use this system in an improper way, it may cause danger which will result in death or serious injury.
 Warning	If you ignore this indication and use this system in an improper way, it may cause danger which will result in injury.
 Caution	If you ignore this indication and use this system in an improper way, it may cause the occurrence of physical obstacles.
Note	This indication shows any attention or supplement to avoid erroneous operation etc.
	This indication shows any matters to understand this content deeply and the useful information.

Reproduction or reprinting of this instruction manual, either partially or totally, without permission from Tokyo Sokki Kenkyujo Co., Ltd., is strictly prohibited.

The contents of this instruction manual are subject to change without notice for the purpose of product improvement.

If you have any questions or comments regarding contents of this manual such as misdescription, inaccuracy and missing items, please feel free to contact us.

The company and product names referred to in this manual represent trade names or registered trademarks.

This operation manual applies to the software version 1.0.

Safety Precautions



Danger

Do not operate the system in a place where there is flammable gas or flammable steam. This may cause fire.



Danger

It is not recommended for the user to disassemble or remodel the system. Such a do-it-yourself action may cause an electric shock or a malfunction.



Danger

Never connect the grounding cable to a gas pipe. In addition, make it a rule to disconnect the power supply cable before connecting or disconnecting the grounding cable. There is danger of a fire and the electric shock.



Danger

The noise filter is built into this system to prevent the noise mixing from the power supply line. This filter may cause a liite leakage current. Please ground it for the electric shock prevention. Using two or more this system at a time installed in a rack will cause increase of the leakage current proportionally. Please pay special attention.



Caution

Powder or dust inside the system may cause poor contact or a lowered insulation effect in the connector. Pay special attention, during use and storage, not to allow dust to enter the system.



Caution

Do not subject the system to excessive vibration while in operation. Do not subject it to strong impacts, such as by dropping, during transportation. Strong impacts or vibrations may cause malfunctioning of the system.



Caution

The system may malfunction if either the unit or its wiring is placed near such machines as a large motor, crane, transformer, or welding machine. When extending the sensor to a place subject to a strong electric field, such as near a power substation or radio transmission station, use a special cable such as a shielded cable.



Caution

The system is vulnerable to the dielectric effect of thunderbolts. Take preventive measures against thunderbolts where applicable. Contact your dealer or Tokyo Sokki Kenkyujo Co., Ltd.for details.



Caution

Power supply ON/OFF operation becomes a source of stress, so please do this operation after the interval of five seconds or more.



Caution

Operate the system at a specified temperature. If the operating site is exposed to direct sunlight or an extremely low temperature, arrange for shade or a thermal insulating material.



Caution

Operate the system at a humidity less than 85%. Do not expose it to rain or extreme humidity. When water flowed into the system or system is flooded, dry enough before turning on the power supply. If the system does not start normally, some trouble might be caused. Please contact us.



Caution

Sudden changes in temperature may cause dew condensation. Leave the system in the desired operation site for a certain length of time before turning on power supply. Do not leave it for long in direct sunlight or freezing temperatures.



Caution

The housing of this system has ventilation holes to prevent overheating. Do not close these holes nor insert foreign objects such as metals through these holes.



Caution

When the housing of this system needs cleaning, wipe it with a soft cloth soaked in a dilute solution of neutral detergent, then dry it well with a cloth. Never use strong solvents such as thinner, which may melt or change the color of the surface coating.

TABLE OF CONTENTS

NOTICE

Safety Precautions

TABLE OF CONTENTS

Chapter 1 Overview

1.1 Overview	1 – 2
1.2 Features	1 – 2
1.3 System block diagram	1 – 3
1.4 Description of each part	1 – 4
Channel unit	1 – 4
Control unit	1 – 5
Control panel on side surface	1 – 6

Chapter 2 Turning ON the power supply

2.1 Connection of power supply and grounding wire	2 – 2
Power supply	2 – 2
Reset of breaker	2 – 3
Connection of grounding wire	2 – 4
Cautions and measures for measurement at field and long-term measurement	2 – 4

Chapter 3 Connection of input

3.1 Connection of various sensors	3 – 2
Wire connection method	3 – 2
3.2 Connection method of strain gauge	3 – 4
Quarter bridge 3-wire method	3 – 4
Half bridge method	3 – 4
Full bridge method	3 – 4
Measurement of large strain	3 – 5

Chapter 4 Connection of PC

4.1 Connection with PC	4 – 2
4.2 When 2 or more sets are connected	4 – 3
4.3 Setting of IP address	4 – 4

Chapter 5 Example of operation

5.1 Settings required before measurement	5 – 2
Flow chart of settings	5 – 2
Setting of low pass filter	5 – 3
5.2 Sampling speed	5 – 4

Chapter 6 Precautions on measurement

6.1 Precautions on measurement	6 – 2
--------------------------------------	-------

Chapter 7 Before requesting the repair

7.1 LED does not light up	7 – 2
7.2 Error LED lights up	7 – 2
7.3 Setting cannot be carried out	7 – 2
7.4 Measurement stops	7 – 2

Chapter 8 Specifications

8.1 Specifications	8 – 2
8.2 Standard accessories	8 – 3
8.3 External drawing	8 – 4

Chapter 1

Overview

1.1 Overview	1 - 2
1.2 Features	1 - 2
1.3 System block diagram	1 - 3
1.4 Description of each part	1 - 4

1.1 Overview

This device is a multichannel digital dynamic strain meter that can measure up to 50 channels per one set. It can measure strain, voltage, and thermocouple. It supports the measurement of approximately 100Hz dynamic phenomenon. Connecting devices with LAN cables enables the measurement of up to 20 sets and 1000 channels.

1.2 Features

- Sampling measurement for 50 channels at the same time
- Measurement by up to 20 sets (1000 channels) is enabled
- Maximum sampling speed 1kHz
- Strain, voltage, thermocouple can be measured
- 120 Ω , 350 Ω bridge boxes are built in the device

1.3 System block diagram

This device is connected to PC with an included LAN cable. You can carry out the operation of system and the confirmation of measurement data with measurement / processing software that has been installed in the PC.

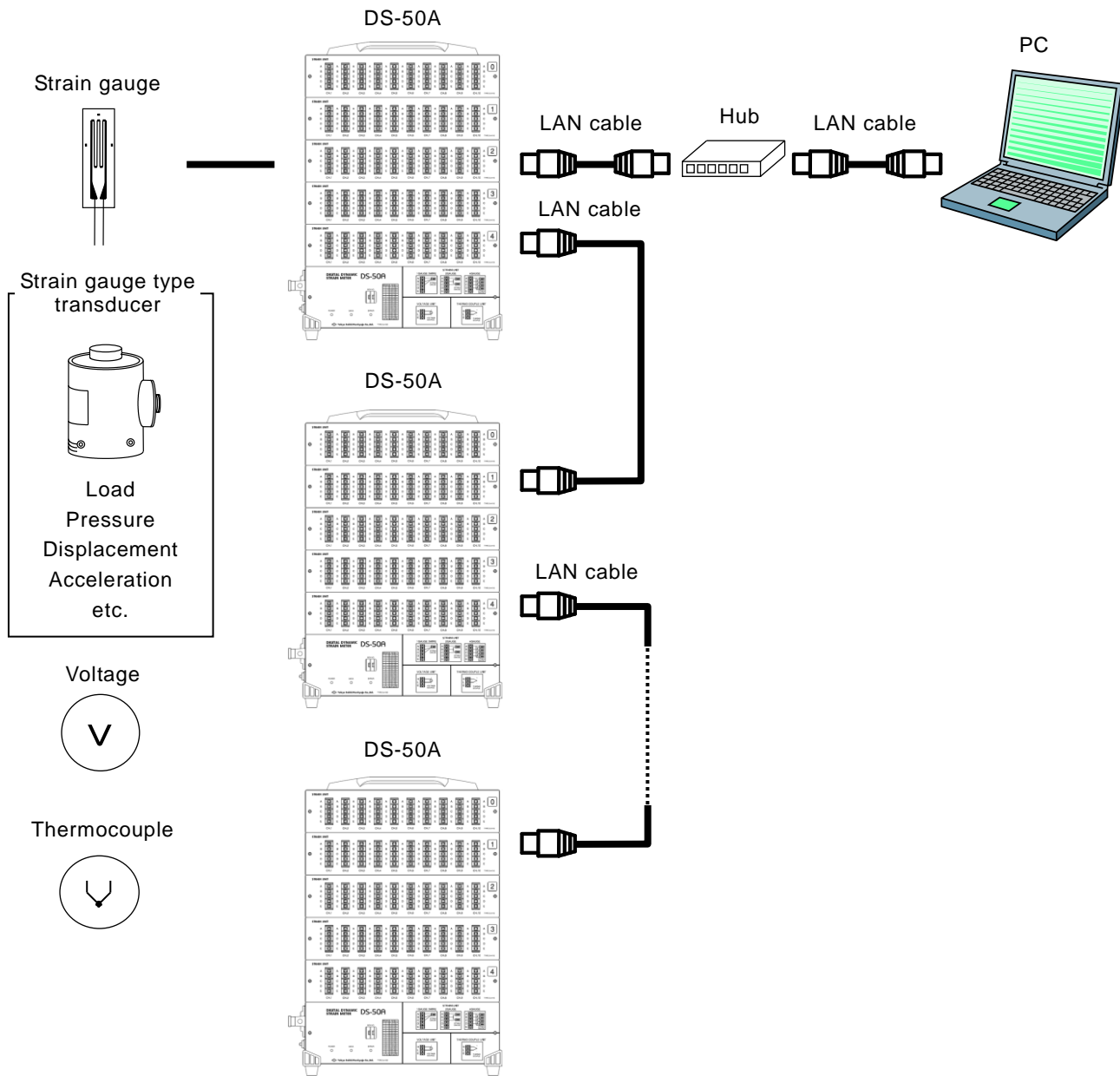

Up to 20 sets can be connected

1.4 Description of each part

■ Channel unit

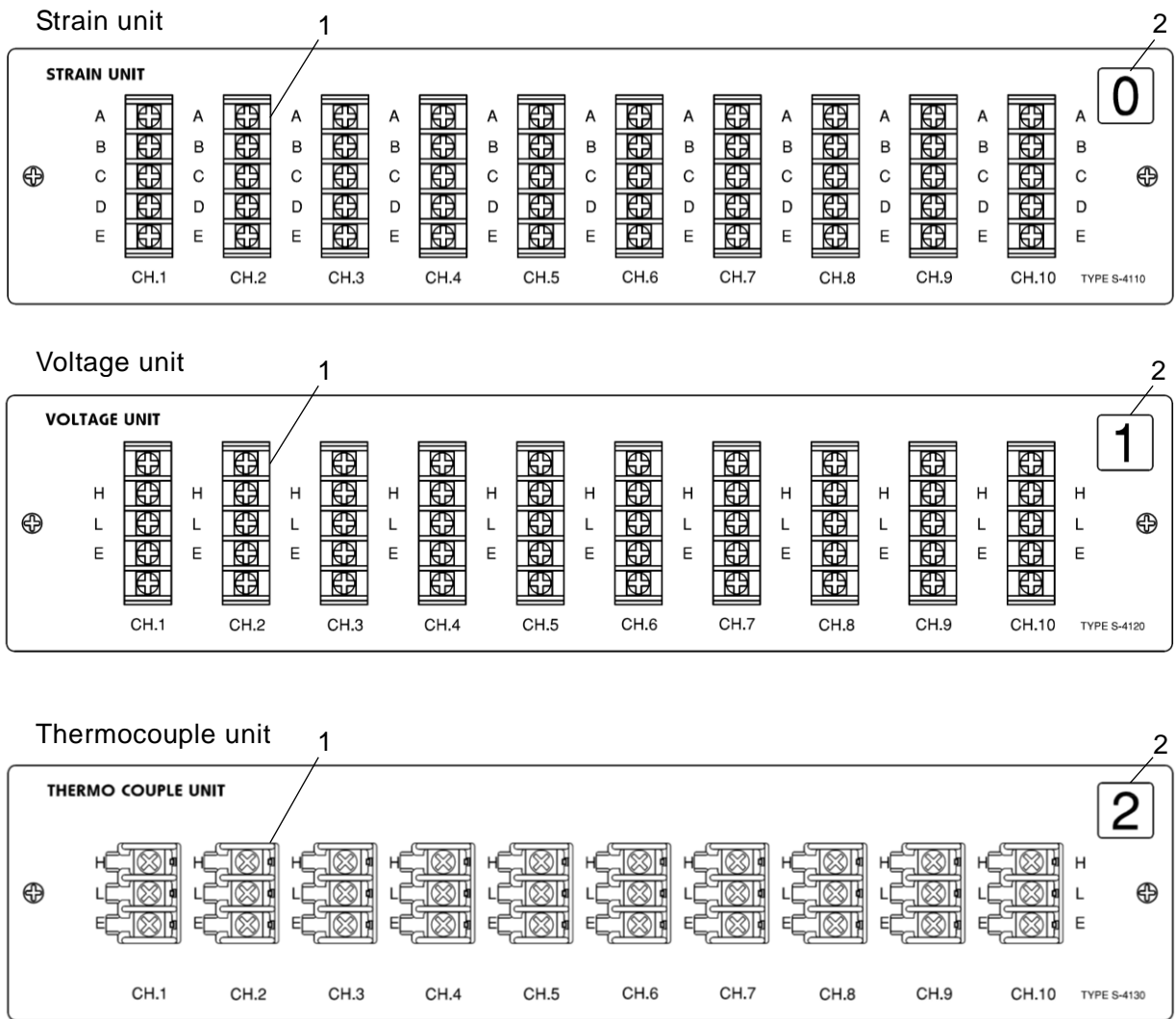

1: Input terminal

Terminal block for connecting the input of strain gauge, strain gauge type transducer, and voltage etc.

2: Unit number sticker

Sticker for identifying the unit number. The channel number is calculated from the channel number, unit number and box number.

■ Control unit

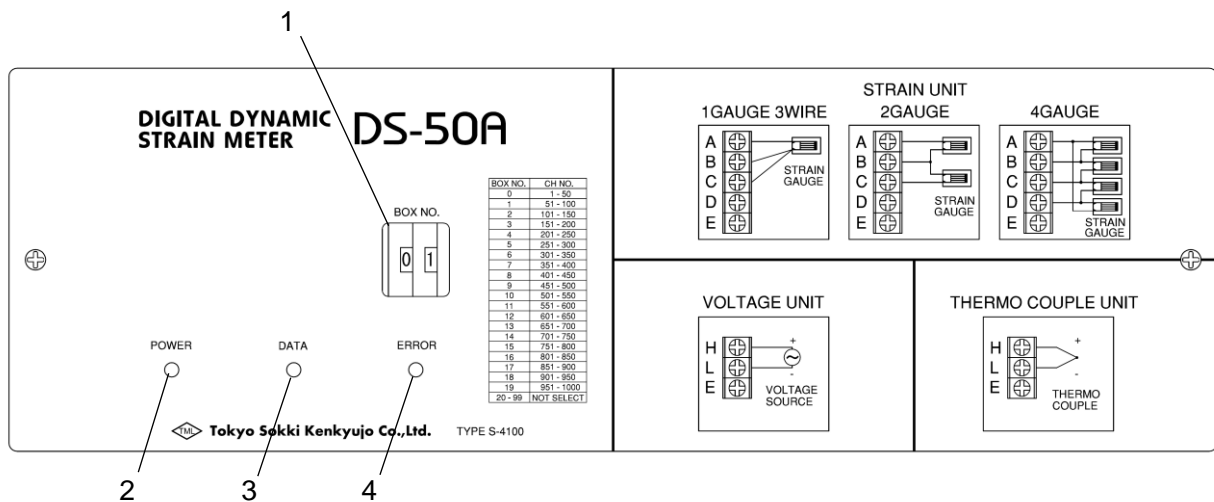

1: BOX No. switch

Switch for deciding the box number. It is necessary to carry out the setting when more than one DS-50A is used. If only one DS-50A is used, set it to "00".

"00" to "19" can be set. If the setting value is out of the range, ERROR LED lights up and the measurement is not carried out. If the box number is set to "00", the channel number of the DS-50A is set within the range of 1 to 50 channels. The channel number is calculated from the box number and unit number.

Calculation formula of channel number

$$\text{Channel number} = \text{CH number} + \text{Unit number} \times 10 + \text{Box number} \times 50$$

For example, when the BOX. NO. is set to "01", channel number of CH.1 in the Unit number 2 is calculated as follows.

$$1 + 2 \times 10 + 1 \times 50 = \text{channel number 71}$$

2: POWER LED

Lights up in green when the power supply is turned ON

3: DATA LED

Lights up in green when the data is transferred to PC. If the data is transferred to PC by using more than one DS-50A, it lights up in red.

4: ERROR LED

Lights up in red when the line to PC is disconnected or various setting errors are generated during measurement. If the box numbers are the same when multiple DS-50A are used, it lights up in green.

■ Control panel on side surface

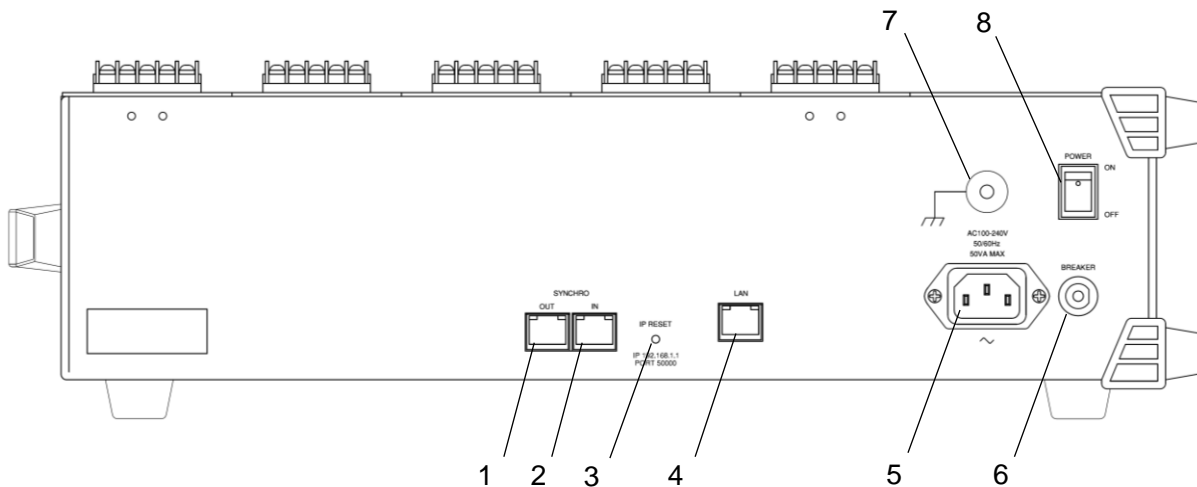

- | | |
|--------------------------|--|
| 1: SYNCHRO OUT connector | Connector for synchronous communication to be used when multiple DS-50A are used. Connected to "SYNCHRO IN" of the next DS-50A. |
| 2: SYNCHRO IN connector | Connector for synchronous communication to be used when multiple DS-50A are used. Connected to "SYNCHRO OUT" of the previous DS-50A. |
| 3: IP RESET switch | If you press the switch when this device is operating, IP address and port number are temporarily reset to the initial values. This switch is used when the IP address of this device is unknown. If you turn ON the power supply while pressing the switch, the mode shifts to the firmware upgrading mode. |
| 4: LAN connector | LAN connector that performs data communications with PC. It is connected to PC with LAN cable via hub. |
| 5: AC power connector | Connected to AC100 to 240V (50/60Hz) line with the supplied cable |
| 6: BREAKER RESET switch | Reset switch of breaker for AC power supply input |
| 7: GND terminal | Terminal for grounding this device |
| 8: POWER switch | Power supply ON/OFF switch |

Chapter 2

Turning ON the power supply

2.1 Connection of power supply and grounding wire 2 - 2

2.1 Connection of power supply and grounding wire

■ Power supply

AC power supply specification of this device is AC 100 to 240V 50/60Hz.

Before connecting the power supply, be sure to check the power supply voltage.

V1 to V3 shown in the figure are voltmeters (tester etc.) of AC range. The specified voltage is shown below.

V1 : within the range 100 to 240V

V2+V3 : 240V or less

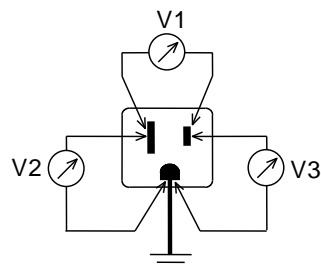

If the outlet is not 3P type, V2 and V3 should measure the voltage between each of them and the ground respectively

To supply the power, be sure to use the power cable supplied to this device (CR-01). When connecting the cable, check that the power switch on the side surface of this device is set to OFF.

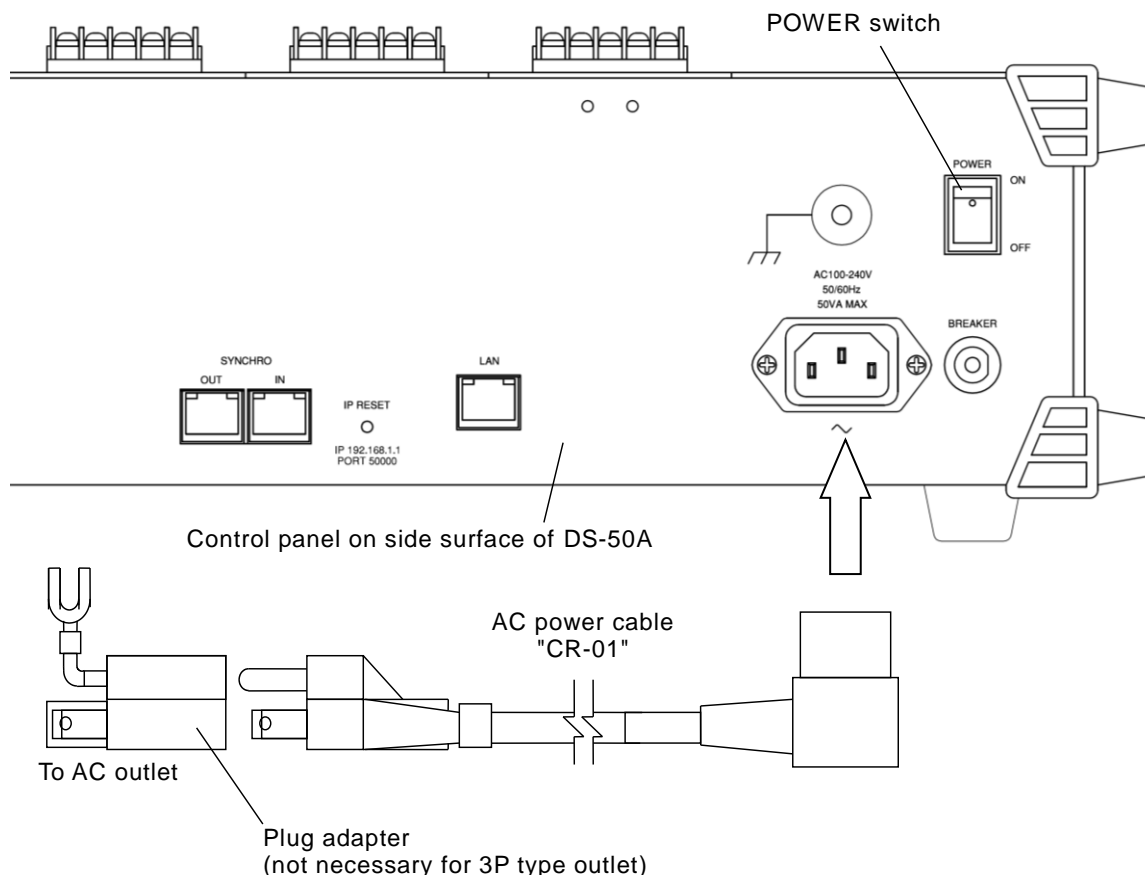

■ Reset of breaker

Reset the breaker by disconnecting the power cable of this device and disconnecting the connection cable for other device. If you press the BREAKER RESET switch while the power supply is turned ON, overcurrent may flow into the device and it is dangerous. If the device does not operate after the breaker is reset, please contact us.

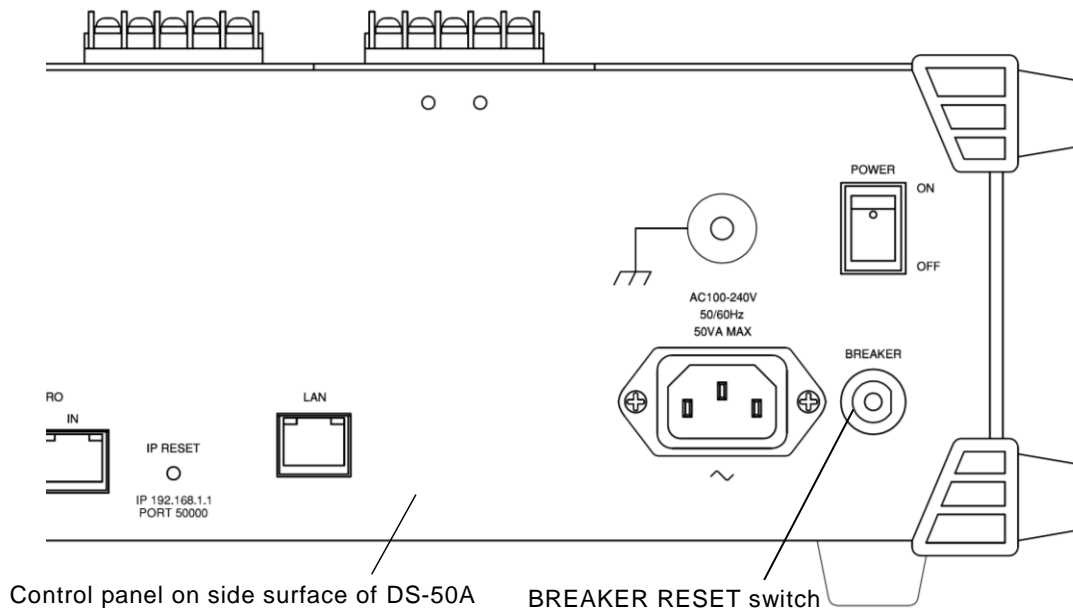

The breaker is reset by pushing the black protrusion in the center of the breaker.



Caution

Reset the breaker after the power cable and the connection cable for other device are disconnected. Otherwise, a failure may be caused.

■ Connection of grounding wire

To prevent the entry of noise or ham from input line, be sure to connect the grounding wire properly. In addition, a line filter is set in this device to prevent the noise from power supply line. In order to prevent the electric shock due to leakage current of the filter, be sure to ground the device.

The grounding wire should be taken from GND terminal on the side surface. For the grounding wire, use our genuine part "CR-20" or equivalent item.

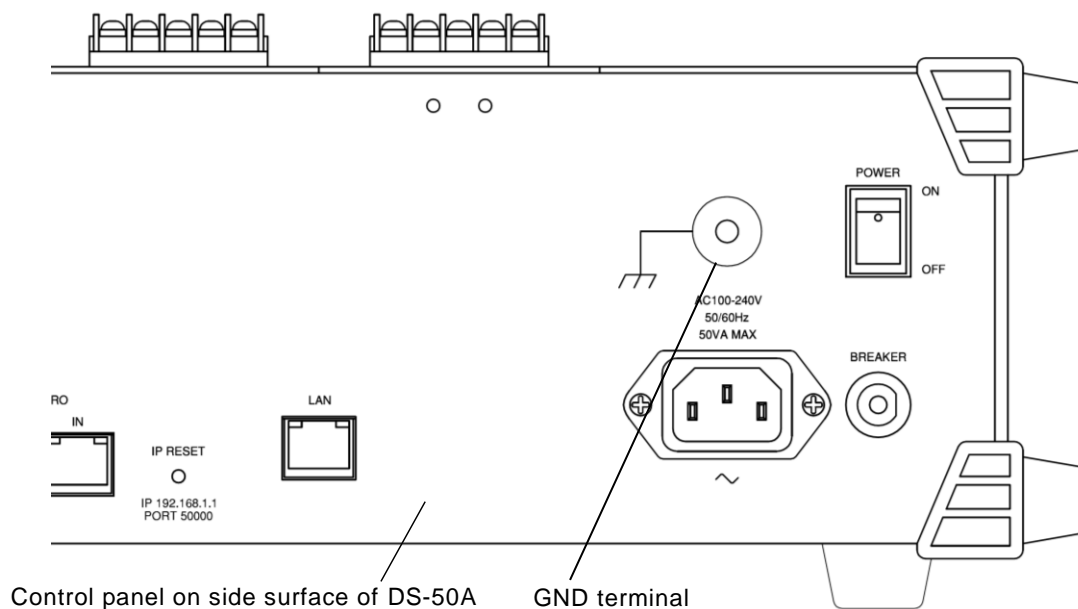

■ Cautions and measures for field measurement and long-term measurement

In case of measurement in the field or equivalent, there may be various problems such as low or unstable voltage of the commercial power supply, power failure, or the influence of noise caused by thunderbolts and heavy machinery. The measures for such problems are shown below.

- Use a step-up transformer
This is the simplest measure when the power supply voltage is low. However, it is necessary to adjust the power supply voltage for the voltage fluctuation manually.
- Use an AC stabilized power supply
The output voltage is automatically kept constant for the fluctuation of power supply voltage. However, if the power supply voltage is lower than the specifications of the stabilizing device, the output fluctuates.
- Use an uninterruptible power supply
There are models with stabilized power supply function that are effective when electric power failure or instantaneous power failure is frequently generated. However, they have built-in large capacity battery, so the size is large and the weight is heavy.

Chapter 3

Connection of input

3.1 Connection of various sensors	3 - 2
3.2 Connection method of strain gauge	3 - 4

3.1 Connection of various sensors

A channel unit dedicated to each sensor is required for connecting the sensor. There are three types of channel units; strain unit, voltage unit, and thermocouple unit.

To connect the strain gauge type transducer, the sensor cable must be without connector.

Type of channel unit	Feature
Strain unit	Dedicated to strain gauge and strain gauge type transducer measurement
Voltage unit	Dedicated to voltage measurement
Thermocouple unit	Dedicated to thermocouple measurement

NOTE Do not tighten the sensor wire with a screw excessively.

■ Wire connection method

The wire connection methods for various sensors are shown below.

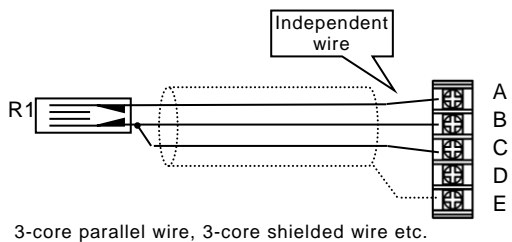
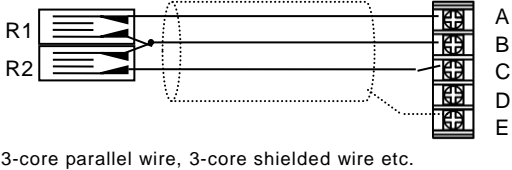
Measurement method	Applicable sensor mode	Wire connection diagram
Quarter bridge 3-wire method * Only strain gauge unit	1G3W 120Ω Gauge resistance 120Ω 1G3W 350Ω Gauge resistance 350Ω * If it is used for quarter bridge 2-wire method, short-circuit between B-C terminals.	
Half bridge method * Only strain gauge unit	Half bridge Gauge resistance 120Ω to 1000Ω	

NOTE D terminal is not used for quarter bridge 3-wire method and half bridge method. Carry out the wire connection carefully.

Measurement method	Applicable sensor mode	Wire connection diagram
Full bridge method * Only strain gauge unit	Full bridge Gauge resistance 120Ω to 1000Ω	
Thermocouple temperature measurement * Only thermocouple unit	T(CC) -200°C to +350°C K(CA) -200°C to +1200°C J(IC) -200°C to +750°C	Internal RJC ON Terminal should not be exposed to wind or direct sunlight. Thermocouple + - H L E For multi-point measurement, insulate the tip as much as possible. Compensating lead wire for thermocouple T-GS-0.65 (shielded wire for T) etc.
		Internal RJC OFF Usual lead wire Thermocouple + - H L E External reference contact (0°C)
Voltage measurement * Only voltage unit	+20V to -20V	Voltage source + - H L E

NOTE The voltage measurement using an attenuator cable is not available for strain unit. Use the voltage unit.

NOTE An open check function is not mounted on strain unit and voltage unit. The measurement value at open indicates indefinite value for strain unit and approx. 1.4V for voltage unit.



CAUTION

With this device, it is not insulated between channels (It is insulated between units).

In multi-point measurement of thermocouple, ham noise may be induced in the measurement value if the insulation of thermocouple lowers. Take care not to lower the insulation of thermocouple.

In voltage measurement, short-circuit may be caused if the voltage source is connected in wrong polarity. Do not mistake the polarity.

3.2 Connection method of strain gauge

Feature and temperature compensation of wire connection method available for this device are shown below.

■ Quarter bridge 3-wire method

The effect of lead wire in quarter bridge 2-wire method is compensated by using 3 parallel wire for the connection. Since the resistance of lead wire enters the fixed resistance side as well as the strain gauge side of the bridge circuit, the effect of initial unbalance caused by the lead wire is eliminated and the temperature of lead wire can be also compensated. However, the temperature compensation of strain gauge cannot be performed.

■ Half bridge method

Built-in fixed resistors are used for 2 arms of bridge circuit. For the strain gauge, two strain gauges of the same lot are used. For the connection, 3 parallel wire is used. The temperature effect of strain gauges and lead wire can be compensated at the same time and the effect of initial unbalance caused by the lead wire is eliminated.

■ Full bridge method

In this method, all of 4 arms of bridge are configured with strain gauges without using the built-in fixed resistors.

Though, this measurement method is not commonly used in general stress measurement, it is used for transducers or to increase the output in torque or bending measurement. In this case, if the bridge is configured at the position where the strain gauges are installed, the effect of initial unbalance and temperature by lead wire is eliminated even if the lead wire is extended.

■ Measurement of large strain

When measuring strain using strain gauge, usually a Wheatstone bridge which incorporates the strain gauge in its arm is assembled to measure the changes in the strain gauge resistance.

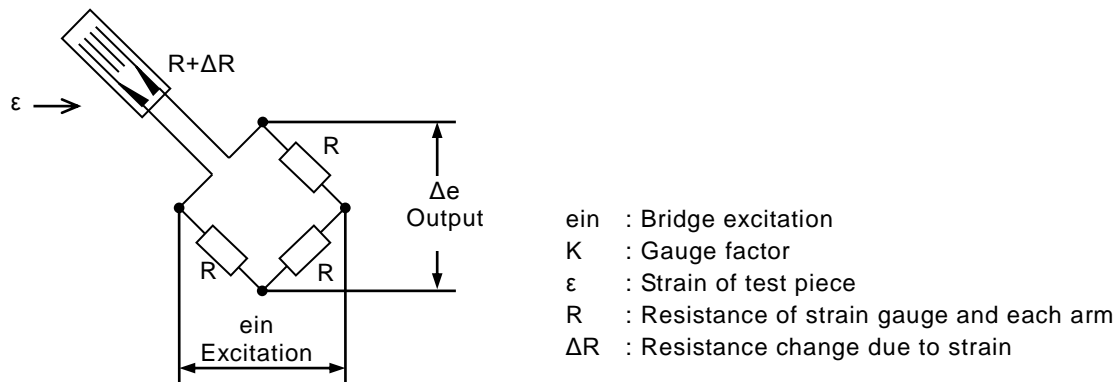

When one arm of the bridge is a strain gauge as shown in the figure above, the output voltage Δe is calculated by formula 1 shown below.

$$\Delta e = \frac{e_{in} \cdot \Delta R}{2(2R + \Delta R)} = \frac{e_{in} \cdot K \epsilon}{4 + 2K \epsilon} \quad (\text{formula 1})$$

If gauge factor $K=2$ and bridge excitation $e_{in}=2V$, the formula 1 gives

$$\Delta e = \frac{\epsilon}{1 + \epsilon} \quad (\text{formula 2})$$

and Δe is not correctly proportional to ϵ .

True strain value	Error
1000×10^{-6} strain	Approx. 0.1%
10000×10^{-6} strain	Approx. 1%
100000×10^{-6} strain	Approx. 9%

If the measurement is carried out in a range where ϵ cannot be ignored for 1 in one active gauge measurement method (in which change of resistance by strain is applied to only one gauge), the non-linearity correction is required.

Carry out the correction by formula 3 as occasion demands.

$$\epsilon = \frac{\Delta e}{1 - \Delta e} \quad (\text{formula 3})$$

Chapter 4

Connection of PC

4.1 Connection with PC	4 - 2
4.2 When 2 or more sets are connected	4 - 3
4.3 Setting of IP address	4 - 4

4.1 Connection with PC

The control and the acquisition of measurement data are carried out from the previously installed software by connecting a PC. For the installation of software, refer to the instruction manual of the software.

For a LAN cable, use "100BASE-TX". Prepare the supplied LAN cable (straight) or a LAN cable and a hub that fulfill the specifications separately, and connect the device with a PC as shown in the figure below. The connection protocol is TCP/IP. For the LAN setting on PC, refer to the instruction manual of Windows.

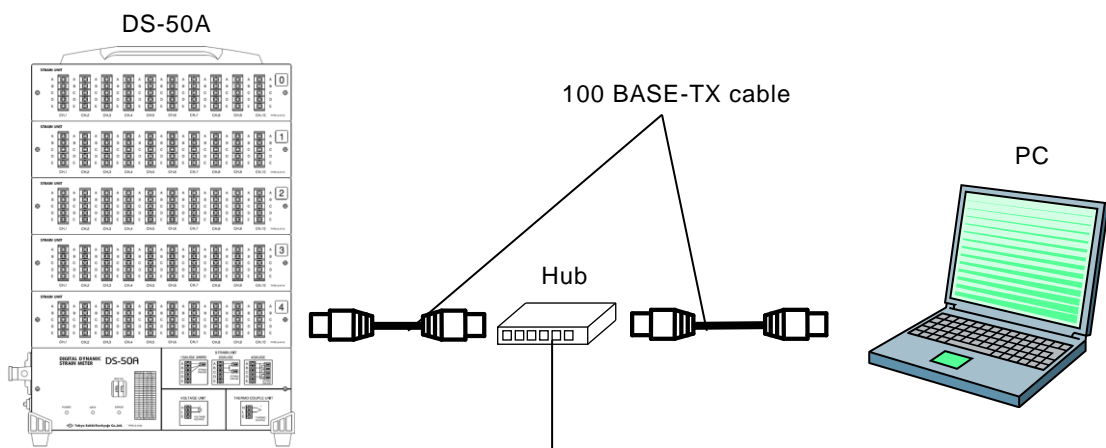

Note on hub

When the device is connected to PC using a straight cable or cross cable on a one-to-one basis, the communications may not be performed depending on the PC. Configure the system via hub as much as possible.



CAUTION

At the measurement, use the dedicated LAN line. If a PC or LAN equipment that is not used for measurement is connected to the line, the communication speed decreases and the measurement may be interrupted. If the application other than the measurement software is operated during the measurement, the communication speed decreases and the measurement may be interrupted depending on the environment. Do not activate other application.



CAUTION

Do not disconnect the LAN cable during communications with a PC. If disconnected, it may be necessary to reboot the system. If the power supply voltage decreases or electric power failure is caused during communications, the following communications may be disabled. Pay attention to the power supply sufficiently.

4.2 When 2 or more sets are connected

Up to 20 devices can be connected. Connect "SYNCHRO OUT connector" of 1st set connected to PC and "SYNCHRO IN connector" of 2nd set with a LAN cable (straight). Connect the sets after 2nd set in series. Do not connect the SYNC IN connector of the master (1st) set.
Next, set the box number. Set different numbers for each device. The box numbers can be set freely, however, the numbers are usually set as 0, 1, 2 ... from the 1st set.

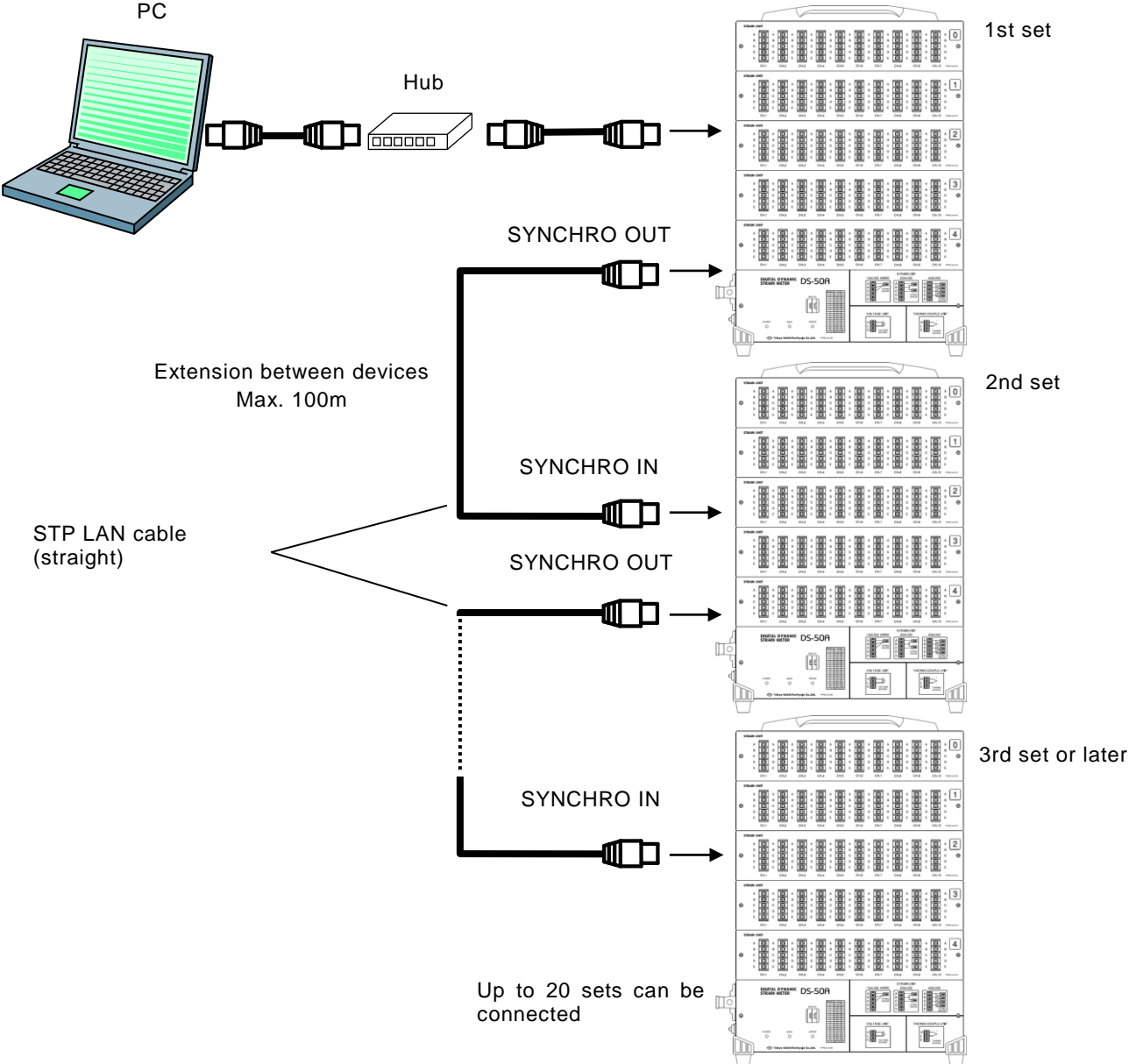

NOTE When you turn ON the power supply, turn ON the power supplies collectively or turn ON the power supply from the first device in series. The 3m LAN cable supplied to this device (CR-6462) can be used as a synchronous cable. If you want to use other length of cable, use STP LAN cable (straight).

4.3 Setting of IP address

The factory setting IP address is "192.168.1.1" and the port number is "50000". The IP address and the port number can be arbitrarily set with the included WINDOWS software. If the IP address of this device is unknown, the IP address can be initialized. If you press the IP address reset switch on side surface of this device for two seconds or more after the power supply is turned ON, the IP address is temporarily initialized.

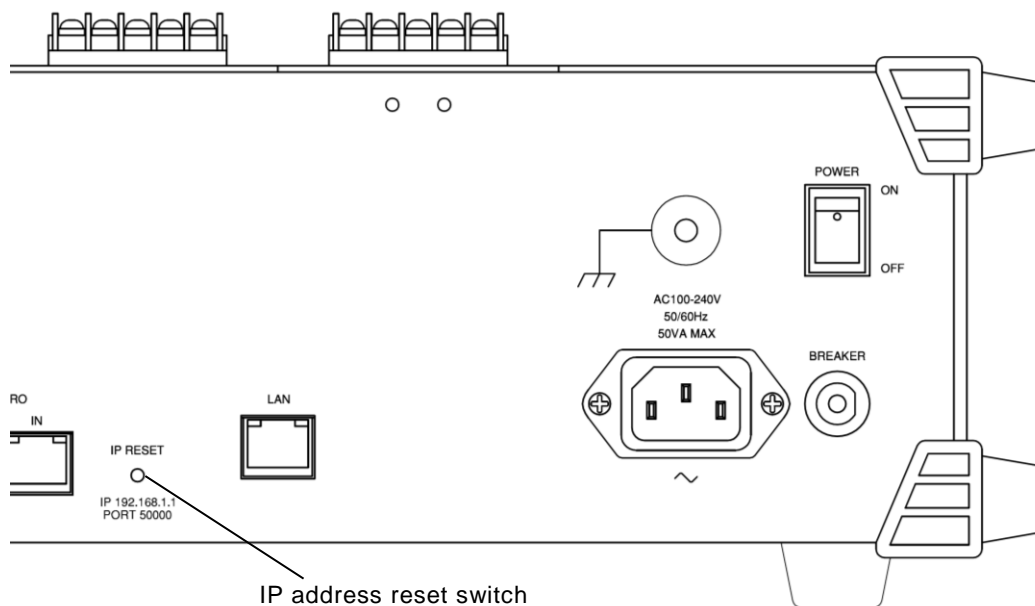

NOTE The IP address setting is required for a device to which PC and LAN cable are connected (1st set). The IP address setting is not required for 2nd set or later.

Chapter 5

Example of operation

5.1 Settings required before measurement	5 - 2
5.2 Sampling speed	5 - 4

5.1 Settings required before measurement

■ Flow chart of settings

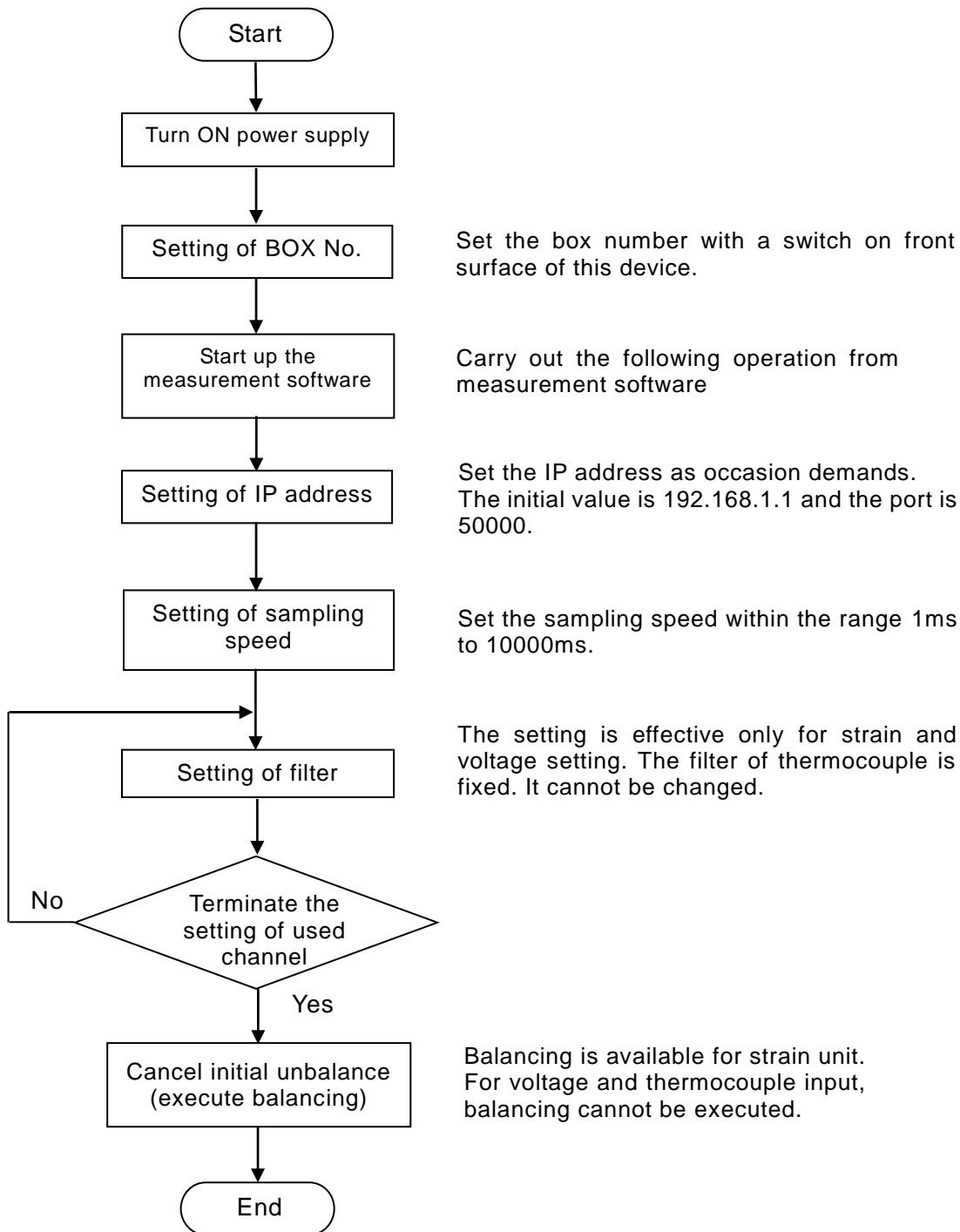

■ Setting of low pass filter

A low pass filter is used for removing the unnecessary high frequency component from a waveform to be measured. A typical characteristic is shown in the figure below. As this device adopts eighth Butterworth filter, the filtering characteristic is sharp. The setting for every 1Hz is available within the range of 1Hz to 100Hz (PASS), so a proper filter can be set for a noise source.

Strain, voltage filter characteristics

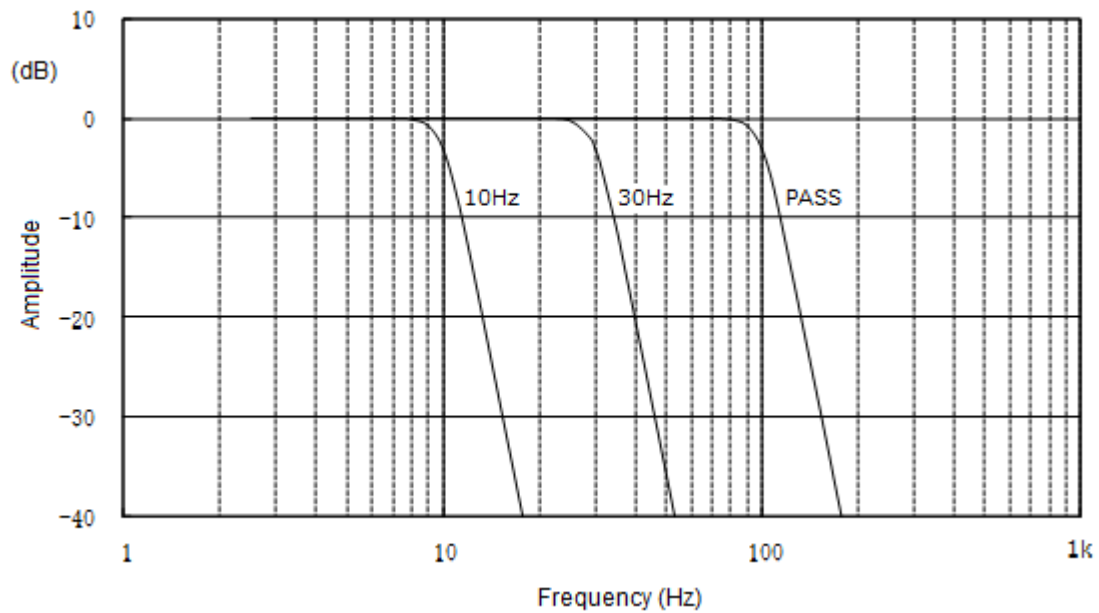

NOTE It is recommended to set the low pass filter to one-tenth or less of sampling frequency.

5.2 Sampling speed

The sampling cycle can be set for every 1ms within the range of 1ms and 10000ms. All channels are measured at the same time in synchronization with the sampling cycle. When up to 20 DS-50A are connected, all channels are measured at the same time in the same way.

The maximum speed of sampling cycle depends on the number of connected sets. If the number of connected DS-50A is one, the settable maximum speed is 1ms. If the number of connected DS-50A is two, the settable maximum speed is 2ms. If the number of connected DS-50A is 20, the settable maximum speed is 20ms.

Chapter 6

Precautions on measurement

6.1 Precautions on measurement	6 - 2
--------------------------------------	-------

6.1 Precautions on measurement

- To fulfill the accuracy of specifications, turn ON the power supply 30 minutes or more before starting adjustment and measurement in order to carry out the warm-up.
- A protection circuit is provided in the bridge excitation. However, if the bridge excitation is short-circuited for a long-time, the circuit may be burned out. Avoid a short-circuit.
- If the insulation resistance of strain gauge is lowered, it may cause ham, noise, and drift. Maintain the insulation resistance at 100MΩ or more.
- Execute the balancing operation carefully. After the initial unbalance is cancelled once, do not execute balancing during the same test or until the necessity to adjust the unbalance value arises again. The previous balanced status is lost and the data becomes meaningless.
- If ham or noise is picked up, the indicated value fluctuates. Ensure the grounding between the object to be measured and the device. If the object to be measured is not grounded, connect it to the ground. Use a shielded wire for a transducer and connect the shield to the grounding terminal on the terminal block.
- If input line and electric power line are wired in parallel, the noise may be mixed, so avoid the parallel wiring. If it cannot be avoided, separate those lines as much as possible.
- If you use the device at power supply voltage lower than the specified value, the device may not operate correctly. If you use the device at a voltage exceeding the specified value, the internal circuit may cause a failure. If the power supply is shared with equipment of heavy load (motor, welding machine etc.), incorrect operation may be caused without being noticed due to short-time voltage drop or noise. Take care not to share the power supply with these devices.
- Avoid the use at dusty place. Especially, the use at the place with much iron powder or concrete powder may cause unexpected failure.
- Take note that the output when a strain gauge or sensor is not connected may be indefinite.
- When an extended cable is used for a sensor, it is recommended to use a twisted-pair shielded wire to minimize the influence of cable capacity by separating A and C signals (bridge input) from B and D signals (bridge output). It may be effective to enable stable measurement for a long term.
- If multiple DS-50A are used, turn ON the power supplies at the same time or turn ON the power supply from the 1st DS-50A in series. If you turn ON the power supply from 2nd device or later, the bridge excitation etc. is not generated, so the device does not operate normally (refer to "4.2 When 2 or more sets are connected").

Chapter 7

Before requesting the repair

7.1 LED does not light up	7 - 2
7.2 Error LED lights up	7 - 2
7.3 Setting cannot be carried out	7 - 2
7.4 Measurement stops	7 - 2

If DS-50A causes a failure or gets defective, check the device following the methods shown below. If the device seems defective after the check, inform your local representative or us of the symptom, check result, and serial number of the DS-50A.

7.1 LED does not light up

- Check the power switch is set to ON (refer to "2.1 Connection of power supply and grounding wire").
- Check the power cable is not disconnected (refer to "2.1 Connection of power supply and grounding wire").
- Check the breaker is not turned OFF (refer to "2.1 Connection of power supply and grounding wire").
- Turn ON the power supply again.

7.2 Error LED lights up

- Check the LAN cable is not disconnected (refer to "4.1 Connection with PC").
- Check the synchronous cable is not disconnected (refer to "4.1 Connection with PC").
- Check PC or LAN equipment that is not used for measurement is not connected to the network (refer to "4.1 Connection with PC").
- Check the box number is set to "00" to "19" (refer to "4.2 When 2 or more sets are connected").

7.3 Setting cannot be carried out

- Check the LAN cable is not disconnected (refer to "4.1 Connection with PC").
- Check the IP address is set (refer to "4.3 Setting of IP address").
- Check the equipment with same IP address does not exist in the network (refer to "4.3 Setting of IP address").

7.4 Measurement stops

If the measurement is stopped unexpectedly, the communications may be unstable due to reason shown below.

The processing of PC cannot be carried out in time.

- Check an application other than measurement/processing software is not executed.
- Check the resident application such as antivirus software is not executed.
- Check the PC that does not fulfill the recommended specifications is not used.

Noise is mixed in the LAN cable.

- When connecting a LAN cable of 5m or longer, use STP cable.
- Carry out the wiring by separating the LAN cable from noise source as much as possible.
- Check this device and PC are grounded properly.

NOTE If the communications are unstable, ERROR LED (red) blinks. If ERROR LED (red) blinks frequently, check the items shown above.

NOTE If the communications are unstable, the measurement data may be damaged. If the data is damaged, the measurement/processing software saves the damaged data as +32767.

Chapter 8

Specifications

8.1 Specifications	8 - 2
8.2 Standard accessories	8 - 3
8.3 External drawing	8 - 4

8.1 Specifications

■ General specifications

Number of measurement points	Maximum 50 points (5 units) / 1 set Strain, Voltage, and Thermocouple units can be mixed together 10 points / 1 unit
Synchronization	Maximum 20 sets (1000 points)
Sampling	1ms to 10000ms (Settable by 1ms unit. Maximum sampling increases by 1ms every time when one set is added)
Interface	LAN (100BASE-TX)
Operating environment	0 to +50°C, 85%RH or less (excluding dew condensation)
AC power supply	Rated voltage 100 to 240V 50/60Hz Allowable power supply voltage 90 to 264V 50/60Hz Maximum power consumption 50VA max
External dimensions	420(W)×110(H)×298(D)mm (excluding projecting parts)
Weight	Approx. 5kg

■ Strain unit

Number of measurement points	10 points
Applicable gauge resistance	Quarter bridge 3-wire 120Ω, 350Ω Half bridge 120 to 1000Ω Full bridge 120 to 1000Ω
Bridge excitation	DC 2V
Measurement accuracy	±0.05%FS (23±5°C)
Measurement range	±25000×10 ⁻⁶ strain
Resolution	1×10 ⁻⁶ strain
Balancing method	Electronic type automatic
Balancing accuracy	±3×10 ⁻⁶ strain or less
Balancing range	±10000×10 ⁻⁶ strain
Stability on zero	Quarter bridge 3-wire ±3×10 ⁻⁶ strain/°C or less Half bridge ±2×10 ⁻⁶ strain/°C or less Full bridge ±1.5×10 ⁻⁶ strain/°C or less
Stability on sensitivity	±0.005%FS/°C or less
Frequency response	DC to 100Hz
Low pass filter	Digital filter
Cut-off frequency	1Hz to 100Hz (Settable by 1Hz unit)
Cut-off characteristic	-3dB±1dB -48dB/oct Butterworth filter
High pass filter	Digital filter
Cut-off frequency	0.2Hz or 1Hz
Cut-off characteristic	-3dB±1dB -12dB/oct

■ Voltage unit

Number of measurement points	10 points
Input type	Single end (unbalanced)
Input impedance	Approx. 100k Ω
Measurement range	$\pm 20V$
Measurement accuracy	$\pm 0.05\%FS$ (23 $\pm 5^{\circ}C$)
Resolution	1mV
Frequency response	DC to 100Hz
Low pass filter	Digital filter
Cut-off frequency	1Hz to 100Hz (Settable by 1Hz unit)
Cut-off characteristic	-3dB $\pm 1dB$ -48dB/oct Butterworth filter

■ Thermocouple unit

Number of measurement points	10 points
Measurement range	T: -200 to +350 $^{\circ}C$ K: -200 to +1200 $^{\circ}C$ J: -200 to +750 $^{\circ}C$
Measurement accuracy	Internal reference junction $\pm(0.5\%rdg+2^{\circ}C)$ External reference junction $\pm(0.2\%rdg+1^{\circ}C)$ (23 $\pm 5^{\circ}C$)
Resolution	0.1 $^{\circ}C$
Response time	20ms or less (0 \rightarrow 90%)

8.2 Standard accessories

Operation manual	1 copy
AC power supply cable 3m (CR-01)	1 piece
LAN cable 3m(CR-6462)	1 piece
Measurement software DS-750	1 piece
Phillips screwdriver	1 piece

8.3 External drawing

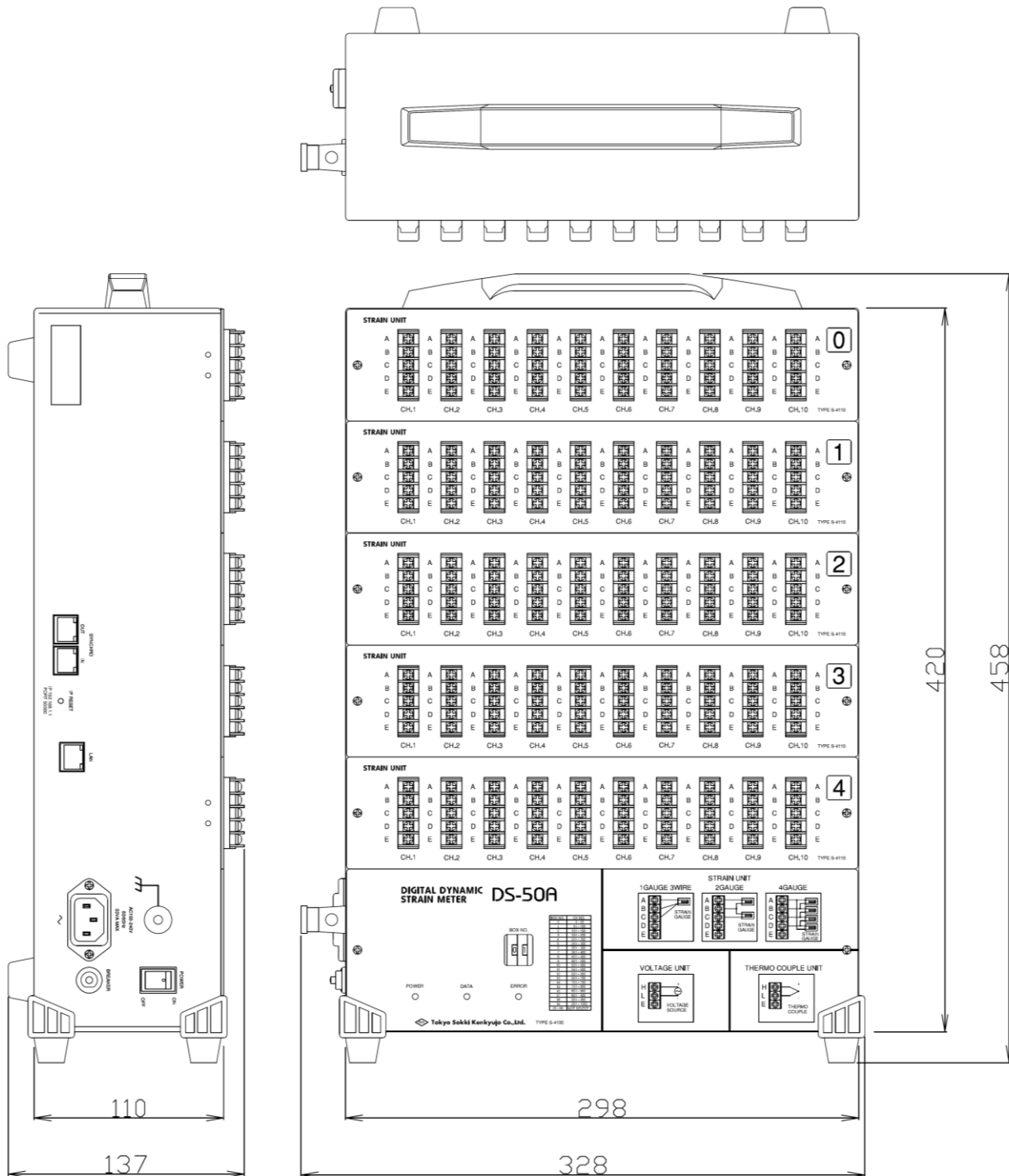

Before Requesting for Maintenance and Service (repair)

If there should be any failure or malfunction of DS-50A, please contact your local representative or Tokyo Sokki Kenkyujo Co., Ltd.

■ When you send us the device for repair and maintenance service:

- For quick and precise repair and delivery service, please let us know the conditions of trouble or likely cause of such trouble.
- When packing the device to return it to us, use the packing material employed upon delivery of the device from us or the equivalent.
- If the device must be adjusted with accessory parts or element attached, make sure to deliver them to us at the same time.

Guarantee

This product has been carefully examined by our in-house inspection division before delivery. If it malfunctions due to a manufacturing fault or an accident during shipment, please report on the condition to your nearest dealer or directly to Tokyo Sokki Kenkyujo Co., Ltd. The guarantee period of this product is twelve months from the date of delivery. If the product goes out of order or is broken during this period, we will repair it free of charge. However, this free guarantee repair service will not apply in the case of trouble or damage caused by improper handling of the product, remodeling or modification by the user, or an act of God. Tokyo Sokki Kenkyujo Co., Ltd. shall not take any responsibility for claims and guarantee of loss and/or damage arising from the operation of this product regardless of any misdescription, inaccuracy or missing items in the contents of this manual

Tokyo Sokki Kenkyujo Co., Ltd.

Head office

8-2, Minami-Ohi 6-Chome, Shinagawa-ku, Tokyo 140-8560, Japan
Tel: +81-3-3763-5614 Fax: +81-3-3763-5713

Multichannel Digital Dynamic Strainmeter DS-50A

1st edition, March 2014

Edited and issued by: Tokyo Sokki Kenkyujo Co., Ltd.

URL: <http://www.tml.jp/e> E mail address: sales@tml.jp

© 2014 Tokyo Sokki Kenkyujo Co., Ltd.